

88M



Model 88M Thru-Spindle ID Gage

One-minute in-spindle
setup time cuts
changeover costs

The latest refinement of Control Gaging's classic quick-setup, thru-spindle gage head is the Model 88M. "Durability" means more to us than the proven ruggedness of our gages in the field: it also means that our products remain leaders in their markets through continuous design and performance improvement.

The 88M is specifically designed to be installed inside the workhead spindle of a high-production internal grinding machine. High-pressure coolant flow and continuous vibration make this one of the harshest of all in-process gaging environments. It is also a difficult application for gage contact setup.

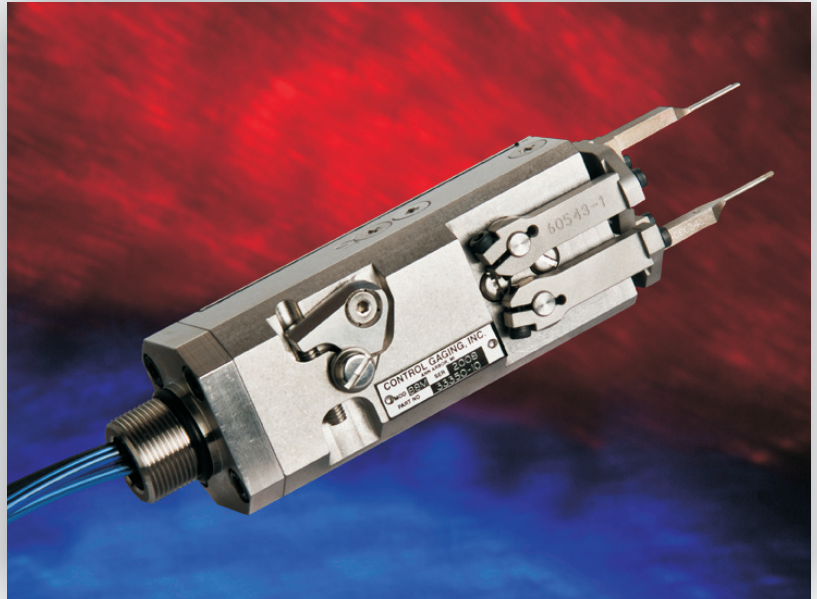

- ✓ Quick in-spindle setup
- ✓ Stainless steel body
- ✓ Integrated air retract, up to 5.1mm /contact
- ✓ 3 quick retract settings + full-range adjustment
- ✓ Gaging range 9.5 - 158mm
- ✓ .0004mm repeatability @ 5.15 sigma
- ✓ Smooth surfaces
- ✓ RoHS Compliant

Control Gaging's exclusive clutch mechanism makes manual setup from the front of the chuck easy and quick, without removing the gage from the spindle. Especially for short run parts, this feature can save significantly on changeover costs.

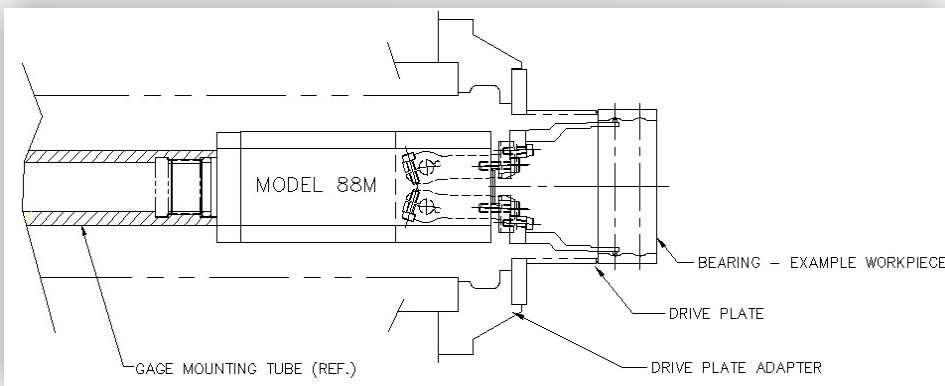

The improved gage design incorporates specific advances based on feedback from customers and service personnel: bearing structure, cable sealing, retract mechanism reliability, and reparability have all been enhanced for performance improvement and life-cycle cost reduction.

TAKE CONTROL & SAVE MONEY

Control Gaging Incorporated

847 Avis Dr. Ann Arbor, Michigan 48108 Phone: +1 734.668.6750 Fax: +1 734.994.1335
www.controlgaging.com Email: sales@controlgaging.com

Model 88M Thru-spindle Gage Head Dimensions

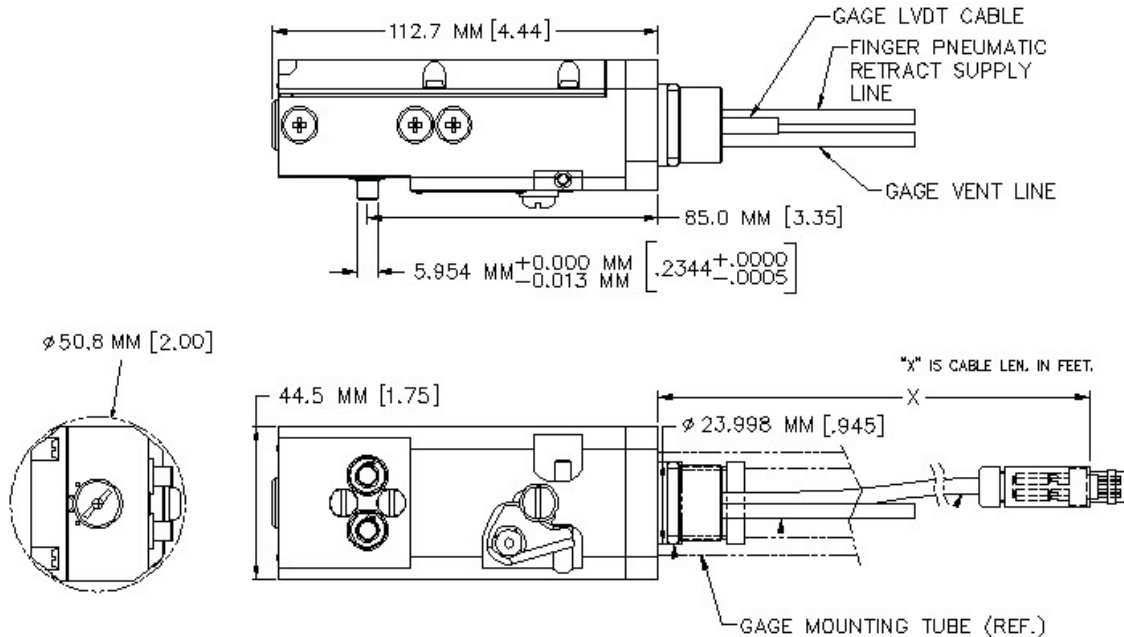

Technical Specifications:

Size Range: 9.5 – 158mm
Surface type: Smooth only
Repeatability: .0005mm @ 5.15 sigma
Maximum Retraction Amount: 4.0 degrees per contact.
 Example: 5.1mm per contact retraction at contact tips using 78mm contact assemblies
Contact Retraction Operating Pressure: 2.8 - 4.1 bar; air ON retracts contacts away from the workpiece
Contact Force: 120 grams at contact tips
Clutch breakaway force: 2400 grams at contact tips
Weight: 1.1 kg
Sealing: IP67

Features:

- Quick-setup clutch – mechanical contact setup in seconds for most sizes
- Stainless steel case and components – durability and corrosion resistance
- Integrated pneumatic contact retraction, up to 5.1mm per contact
- Three standard retraction settings with ability to set limits over full range
- Removable armset: The complete armset assembly is easily removed from the gage housing for speedy repair or replacement.

TAKE CONTROL & SAVE MONEY

Control Gaging Incorporated

847 Avis Dr. Ann Arbor, Michigan 48108 Phone: +1 734.668.6750 Fax: +1 734.994.1335
 www.controlgaging.com Email: sales@controlgaging.com