

Wheel Position Measurement

Measuring the surface of grinding wheels can effectively control part size and grind-line on disc grinders

On disc grinders, direct in-process part measurement can sometimes be extremely difficult. Even if possible, grinding wheels wear at different rates, and may drift out of line with the tooling. Measuring the position of the surface of the grinding wheels has proven to be a realistic solution to both problems.

Control Gaging has used several wheel position gaging techniques successfully, holding part size or wheel location to tolerances within several microns. Using artificial diamonds and timed-interval contact to minimize wear, these techniques can be effective tools in managing disc grinding processes.

The gaging system represented in the figures on this page controls both size and wheel position with two grind-line gages. Part size is calculated as the sum of the two gage readings, which is a measure of the gap between the wheels. As the wheels wear and the sum gets larger, the gage controller will initiate a compensation. However, it first checks the position of each wheel relative to its nominal position - the wheel farthest from nominal is the one that is moved. An alternate method prioritizes the wheel on the fixed-tooling side, maintaining its position relative to the guides and compensating the other wheel secondarily.

Dual wheel sensors are used with Control Gaging's D500 Gage Controller, which is configured for your application and includes field-proven software to help the machine perform to its best capability.

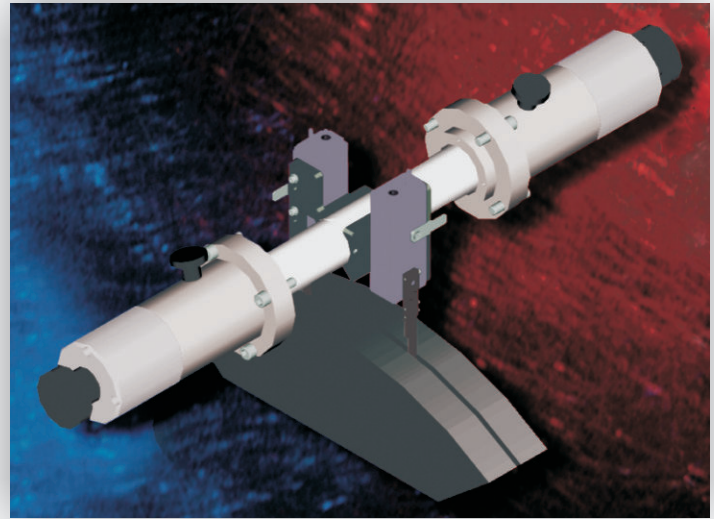

Wheel Measurement Applications

Machine types: Single or double, vertical or horizontal spindle disc grinders

Part size: minimum 4.5mm/.180"

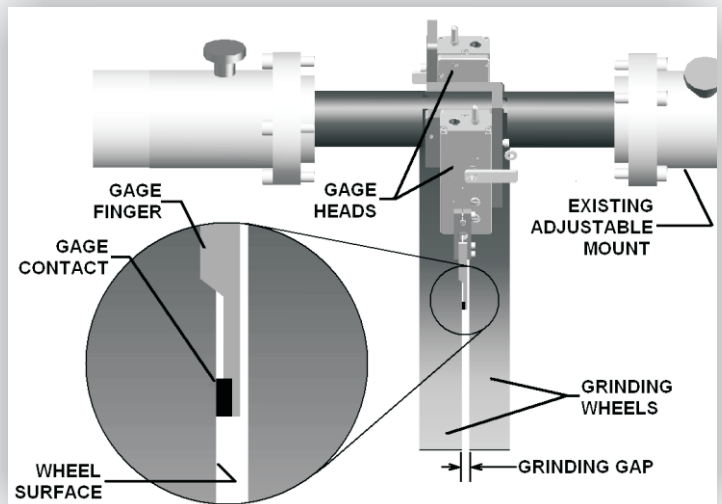

Dual wheel gage on this disc grinder controls grind-line (both wheels) plus part size (by maintaining the correct grinding gap)

TAKE CONTROL & SAVE MONEY

Control Gaging Incorporated

5200 Venture Dr. Ann Arbor, Michigan 48108
www.controlgaging.com

Phone: +1 734.668.6750 Fax: +1 734.994.1335
Email: sales@controlgaging.com

Wheel Measurement



D500 Gage Controller



The D500 is an advanced, highly-configurable gage controller with the power for demanding applications. Advanced DSP technology and software filtering provide fast, precise gaging signals, even on the surface of spinning, coolant-covered grinding wheels.

The D500 can easily handle the more complex Grind Line applications. In one case, a two-transducer gage head measures size in-process, while two single-transducer heads gage the wheel positions. The D500 handles all four readings simultaneously, using the part size gage to control compensations and using customer-selected conditional logic to determine which wheel

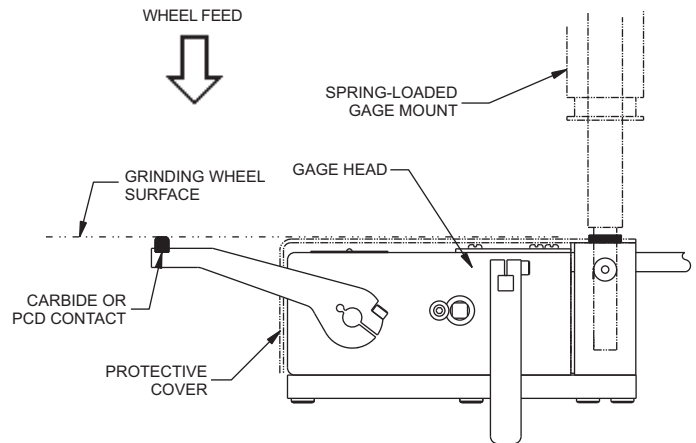

Single wheel position gage on Besley SV6 or V6000 (now made by Giustina) signals the feed endpoint for size control

A unique application is the use of a wheel position gage on the single vertical spindle Besley grinders indicated in the figure above. The machine indexes its table, bringing one or two rotating workstations beneath the grinding wheel, then starts a plunge grind operation.

The gage, mounted to the spindle housing, is contacted near the end of the cycle and signals the infeed to stop and dwell. This application uses the inexpensive D100 controller and can hold tolerances to $005\text{mm}/.0002''$.

Managing gage contact wear in wheel measurement applications

The contact force of a gage is typically set to 90 grams and although this results in very slow wear on a gage contact, the wear can be further reduced by utilizing some or all of the following techniques:

- Interval timing - In some cases the gage contact can be retracted from the wheel for minutes at a time, then dropped for a few seconds onto the surface to take the reading.
- Contact material - PCD (artificial diamond) or carbide can be used depending on the type of grinding wheel.
- Contact surface area - Increasing the contact surface area can decrease the contact wear rate.

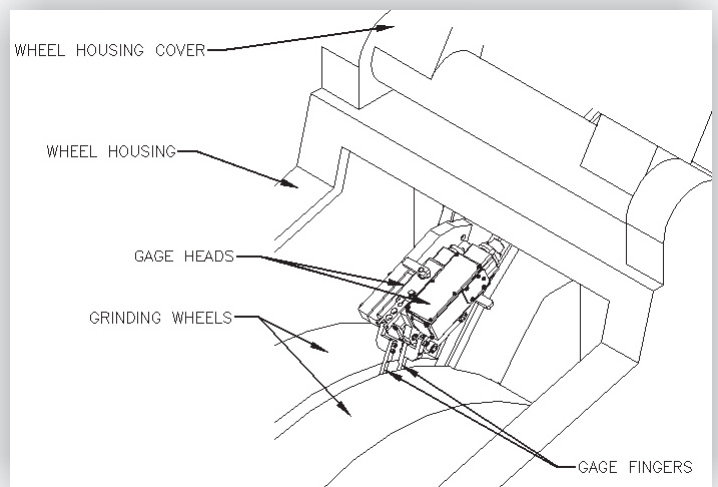

On horizontal spindle machines, gages are accessed from the top. These gages are built rugged to live in this environment.

TAKE CONTROL & SAVE MONEY

Control Gaging Incorporated

5200 Venture Dr. Ann Arbor, Michigan 48108
www.controlgaging.com

Phone: +1 734.668.6750 Fax: +1 734.994.1335
Email: sales@controlgaging.com