

D100



D100 Gage Controller

High-accuracy process control in a compact affordable package

For more than 35 years Control Gaging Inc. has been working directly with the manufacturing engineers who are responsible for high-accuracy, high-volume production grinding.

We have consolidated that knowledge and experience to design the D100 Gage Controller. Aimed at basic, single-feature applications, the D100 responds to accelerating customer requirements while setting new standards for simplicity, accuracy, durability and affordability.

The D100 Controller achieves both its power and its compact size through the inventive application of advanced DSP technology. At the same time it retains the operator-preferred analog meter for visual monitoring of stock-removal rate and cycle disturbances.

In keeping with Control Gaging's worldwide reputation for durability, the D100 is housed in a sturdy metal enclosure and comes with a full two year warranty.



- ID or OD Operation
- Signal filter for smooth or interrupted surfaces
- Metric/Inch analog meter
- Four setpoint outputs
- Two gage inputs - select 1, 2, or 1+2
- Proportional analog output
- Single-button size adjustments
- Remote zeroing
- Remote size offset
- 2440 readings/sec
- RoHS Compliant

The membrane front panel provides a bright and simple user interface. The buttons are grouped by function and the LED's indicate the status of selected features and of I/O. The [+] and [-] buttons are used for adjusting parameters and for instant size adjustments during automatic operation.

Input connections are included for remote zeroing and for remote size offsets, from either a manual pushbutton or a post-process gage. Proportional analog output of size is also standard.

The D100 is available in both stand-alone or panel-mount configurations. See further technical specifications on the reverse.

TAKE CONTROL & SAVE MONEY

Control Gaging Incorporated

5200 Venture Dr. Ann Arbor, Michigan 48108
www.controlgaging.com

Phone: +1 734.668.6750 Fax: +1 734.994.1335
Email: sales@controlgaging.com

D100



D100 Standard Chassis Ref. Drawing D900930D-001

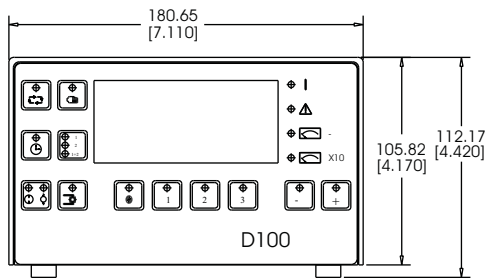

FRONT VIEW

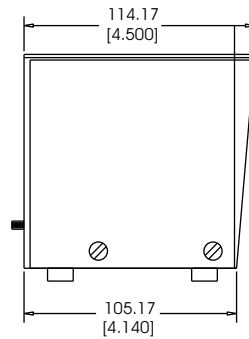

LEFT SIDE VIEW

General Specifications

Weight: 1kg. (2.2 lbs.)
Chassis: IP54
Power: 100-240V ac
 50/60 Hz
 4W
Inputs: 20-30V dc
Setpoint outputs:
 24V dc
 125 mA max.
Analog output:
 +/- 10V dc
 Proportional

D100 Panel Mount Chassis Ref. Drawing D900930D-002

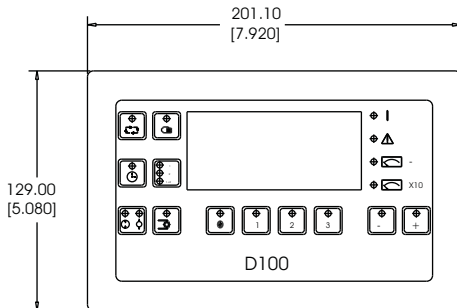

FRONT

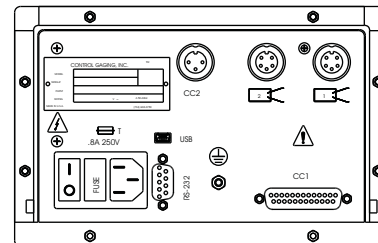

REAR

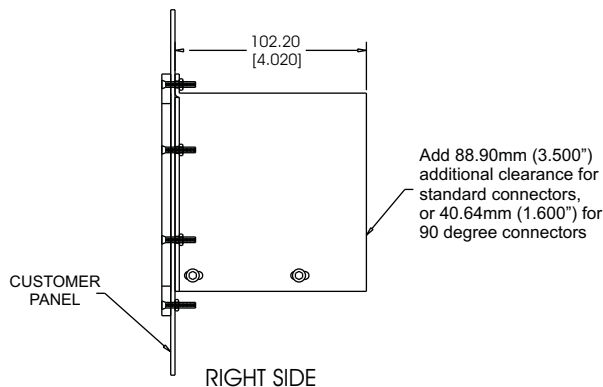

RIGHT SIDE

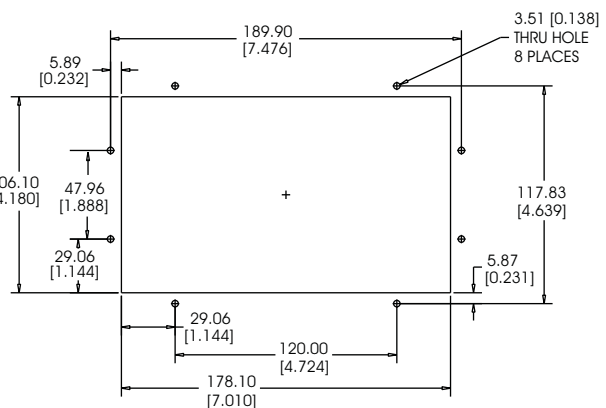

PANEL CUTOUT

TAKE CONTROL & SAVE MONEY

Control Gaging Incorporated

5200 Venture Dr. Ann Arbor, Michigan 48108
 www.controlgaging.com

Phone: +1 734.668.6750 Fax: +1 734.994.1335
 Email: sales@controlgaging.com